

# SOLAR & ELECTRIC MOBILITY INNOVATIONS

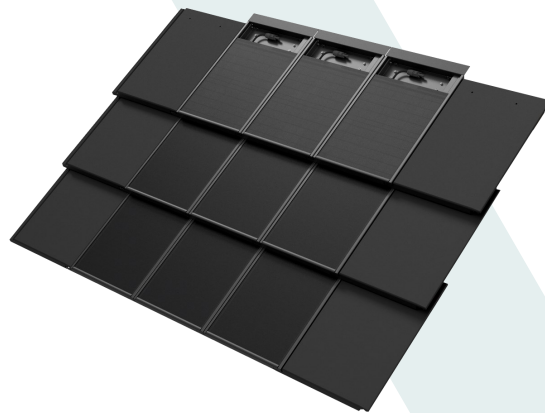

paXos



# TABLE OF CONTENTS

<b>Foreword</b> .....	3
<b>Solar</b> .....	4
Solar Roof Tile Mild-Hybrid.....	4
Solar Roof Tile Accessories.....	6
Solar Beaver Tail Light-Hybrid.....	8
Solar Facade Element.....	10
Solar Water Element .....	12
Solar Agricultural Element Mounting System .....	14
Solar Traffic Route Element.....	16
Junction Box PV .....	18
<b>Electric Mobility</b> .....	20
High Performance Charging System.....	20
Wheel Hub Motor Axial Suspended .....	22
Charging Pole Small.....	24
Charging Pole Tall .....	26
Charging Pole Top-Roof.....	28
<b>Company</b> .....	30
<b>Services</b> .....	31
Consulting.....	31
Think Tank .....	31
Engineering.....	32
Project Management .....	32
Training .....	33
HR Consulting .....	33
<b>Journey Description</b> .....	34
<b>Imprint</b> .....	35

# FOREWORD

Dear Reader,

The world today is full of challenges.

Climate change demands significant reduction of CO<sub>2</sub> emissions. High population pressure demands the best utilization of land for food and energy production. Finite resources (fossil fuels / clean air to breath / land) demand careful usage of these resources.

paXos innovates and develops solutions to overcome these challenges. We are a “think tank” focusing on cleantech: sustainable energy production, practicability of e-mobility and the best utilization of resources and land.

Our motivation is to create the best future for mankind. Our easy-to-use scalable solutions with their proven business cases have the potential to reach many end users.

In this brochure you will find an extract of cleantech solutions - some of them will shortly go into high volume production and others are ideas waiting to unfold.

We are looking for you - dear investor, production partner, sales partner and end user to move with us from concept to production.

Together we can make the world a better place.

## The paXos associates



From left to right:

- › Karsten Birkholz
- › Janina Kaergel
- › Peter Hakenberg
- › Stefan Puczynski
- › Guido Schumacher

## SOLAR ROOF TILE MILD-HYBRID



A stylish integration of the energy revolution into our everyday life, combined with a high-power density and an improved concept in partial shading can be found in the solar roof tile Mild-Hybrid.

In addition to electrical energy, the hybrid system also generates thermal energy that can be used for heating or hot water preparation. The building-integrated photovoltaic system sits inconspicuously on the roof, eliminating the need for double roofing.

### REASONS FOR DEVELOPMENT

The space available for solar energy is currently mostly limited to rural regions or suburbs, where large PV modules can be installed or mounted without shading. In large cities, the problem is crystallizing that there are increasingly jagged roof surfaces that cannot be developed with PV modules.

### SOLUTION

The Solar Roof Tile Mild-Hybrid is a built-



- › Building-integrated, monocrystalline photovoltaic module (BiPV)
- › Hybrid system for electrical and thermal energy generation
- › Optimal utilization of the entire roof surface for energy generation
- › Roofing of listed buildings
- › Integrated rear venting for high performance and durability

ding-integrated photovoltaic system that has the appearance of a conventional roof.

In addition, the entire roof can be used to generate energy, as the system is small-sized and can be customized. Shading is minimized by intelligent interconnection and protection, which increases the overall yield.

## PROMISES

- › **Performance:** Due to back venting, we can promise high performance of electrical and thermal energy over a period of 50 years.
- › **Mechanics:** We have certified our products against hail, storm suction and walkability of the roof.
- › **Quality and Durability:** Due to the glass-glass construction method, the roof remains watertight for 200 years and has a long-term performance with over 50 years.
- › **Installation:** Our modules are easy to lay, connect and exchange.
- › **Environment:** Our focus lies on the sustainability of our products. We increase the useful life and offer very good recyclability.
- › **Additional Benefits:** Matching complementary system available (p. 8), in case of snow and dew on the roof surface, the modules can be thawed, mounting aids facilitate access to the roof surface and increased fire protection via black switchability.



Figure: Cool air warms up as it passes through

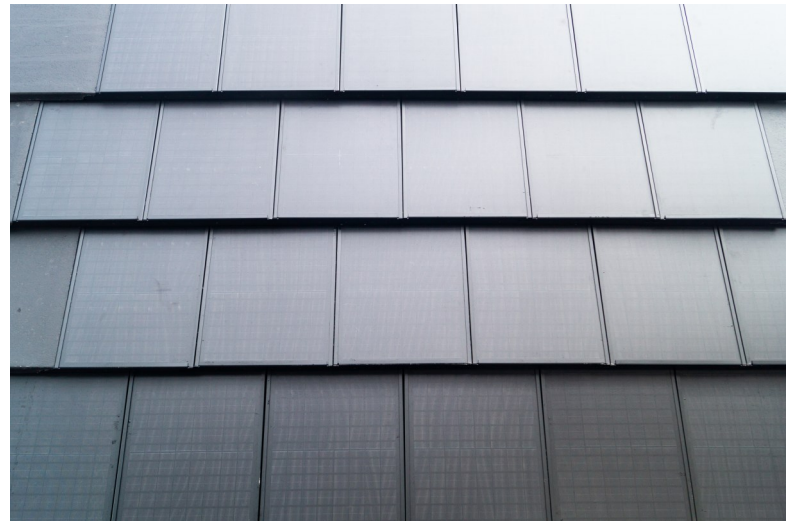

## ADVANTAGES

There is direct access to all major components via sliding glass packs. This makes it easy to replace any module while the roof is covered.

Thermal degradation no longer takes place due to cooling of the glass package. In addition, the heat at the ridge can be made usable via a heat pump.

## TECHNICAL DATA

Parameter	SRT-MH*	
Color	Black, Blue, Terracotta	
Dimensions (L x W x H) [mm]	468 x 331.5 x 30.8	
Clearance Dimensions [mm]	340 x 300 x 30.8	
Junction Box	67 x 75 x 15.7   IP67	
Cable	4 mm <sup>2</sup> , 0.47 m	
Connector	PV4-S	
Mass	2.5 kg	
Wafer	Monocrystalline, PERC	
Open-Circuit Voltage	5.3	V
Short Circuit Current	3.5	A
Nominal Voltage (U <sub>mpp</sub> )	4.5	V
Nominal Current (I <sub>mpp</sub> )	3.3	A
Rated Output (P <sub>mpp</sub> )	14.5	W
Power Density	145	W/m <sup>2</sup>

\*Specifications for black design

## SOLAR ROOF TILE ACCESSORIES



In addition to the development of the hybrid modules, we also offer the complementary accessories that can be used for complete roofing.

### COMPLEMENTARY SYSTEM

Suitable complementary systems to the SRT-MH are available. Neutral traditional flat roof tiles with standard dimensions of 420 x 330 mm can be used, whose dimensions are identical to the SRT-MH.

- › **Ideal addition to the SRT-MH**
- › **Similar appearance**
- › **No need to cover the entire roof surface**

In the visible area of the roof surface, no differences are apparent in this respect. The visual difference is reduced to a minimum. All roof systems offer the same connections, so that installation can take place immediately.



- › Complementary systems are available
- › Similar appearance to the SRT-MH
- › Wave profile to get a classic roof optic
- › Compatible roof steps to get easy on the roof
- › Snow guard modules provide receptacles for snow guard tubes

## WAVE PROFILE



The desired design of the roof can be transformed into a classic roof with the wave profile. In this case, the modules are further apart and are connected by the aesthetic wave. The wave profile is designed in such a way that shading only occurs when the sun is very flat.



## ROOF STEPS

Formed roof steps and snow guard modules complete the accessories. The roof steps are installed in place of solar roof tiles and provide a secure foothold for chimney sweeps, etc. For simple installation purposes, the integrated installation step is usually sufficient.

- › **Sheet metal package with roof steps**
- › **Optimal solution for chimney sweeps**
- › **Easy integration in the roof**



## SNOW GUARD MODULES

For snowy regions, we offer snow guard modules that provide receptacles for snow guard tubes. In connection with the defrost function of the SRT-MH, slipping of so-called roof avalanches can be reliably prevented.

### EXPLANATION: ROOF TILES

There are two different main types of roof tiles that are mostly common: Concrete and clay roof tiles. The clay roof tile is made of, as the name says, clay and is fired at high temperatures. Because of the raw material, there can be color changes within the product.

On the other hand, there is the concrete roof tile, which is made of concrete. Several color grades can be added to the concrete. Made with the extrusion moulding technology, the product is cheaper than a clay roof tile.



## SOLAR BEAVER TAIL LIGHT-HYBRID



For a classic roofing in the style of the beaver tail, the Solar Beaver Tail Light-Hybrid is developed. As a building-integrated photovoltaic module, it has the same appearance as plain tiles.

This means that European buildings with listed structures can be stylishly used for energy production.

### IDEA

The widespread use of plain tiles in some European countries (e.g. Poland) has led to a high demand for this product. Since there are increasing requirements for the protection of monuments on classic roofs, a decisive part of the development is based on the inconspicuous integration into the roof surface.

This also includes the implementation of different color shades and multiple designs.



- › Building-integrated, monocrystalline photovoltaic module (BiPV) with different colors
- › Light-hybrid system for electrical and thermal energy generation
- › Optimal utilization of the entire roof area for energy generation
- › Roofing of historic and listed buildings
- › Easy installation and removal of a single SBT-LH from the compound



## FEATURES

Historic and listed buildings can be covered with SBT-LH during roof renovation. In addition, several designs and colors are provided to easily implement regional differences.

Further product advantages lie in the simple laying and installation of the SBT-LH, which can be detached individually from the composite.

## PROMISES

- › **Performance:** Due to back venting, we can promise high performance of electrical and thermal energy over a period of 50 years.
- › **Mechanics:** We ensure high hail and storm suction resistance as well as walkability of the roof.
- › **Quality and Durability:** Due to the glass-glass construction method, the roof remains watertight for 200 years and has a long-term performance with over 50 years.
- › **Installation:** Our modules are easy to lay, connect and exchange.
- › **Environment:** Our focus lies on the sustainability of our products. We increase the useful life and offer very good recyclability.
- › **Additional Benefits:** Mounting aids facilitate access to the roof surface and increased fire protection via black switchability.

For an efficient dual use of the surface, there is

## LIGHT-HYBRID SYSTEM

an integrated rear ventilation, which allows cooling of the solar cells. The service life of the entire system is significantly increased.

In contrast to a mild-hybrid system, the overall height of the hybrid system is lower, which is why it is referred to simply as a mild-

hybrid system. In this case, the degree of heat utilization is lower at the expense of the aesthetic, uniform appearance.



## TECHNICAL DATA

Parameter	SBT-LH*	
Color	Black, Terracotta	
Dimensions (L x W x H) [mm]	380 x 180 x 12	
Junction Box	IP67 incl. Bypass diode	
Cable	4 mm <sup>2</sup> , 0.47 m	
Mass	1.0 kg	
Wafer	Monocrystalline, PERC	
Rated Output (P <sub>mpp</sub> )	3,3	W
Power Density	120	W/m <sup>2</sup>

\* Specifications for terracotta design

## SOLAR FACADE ELEMENT

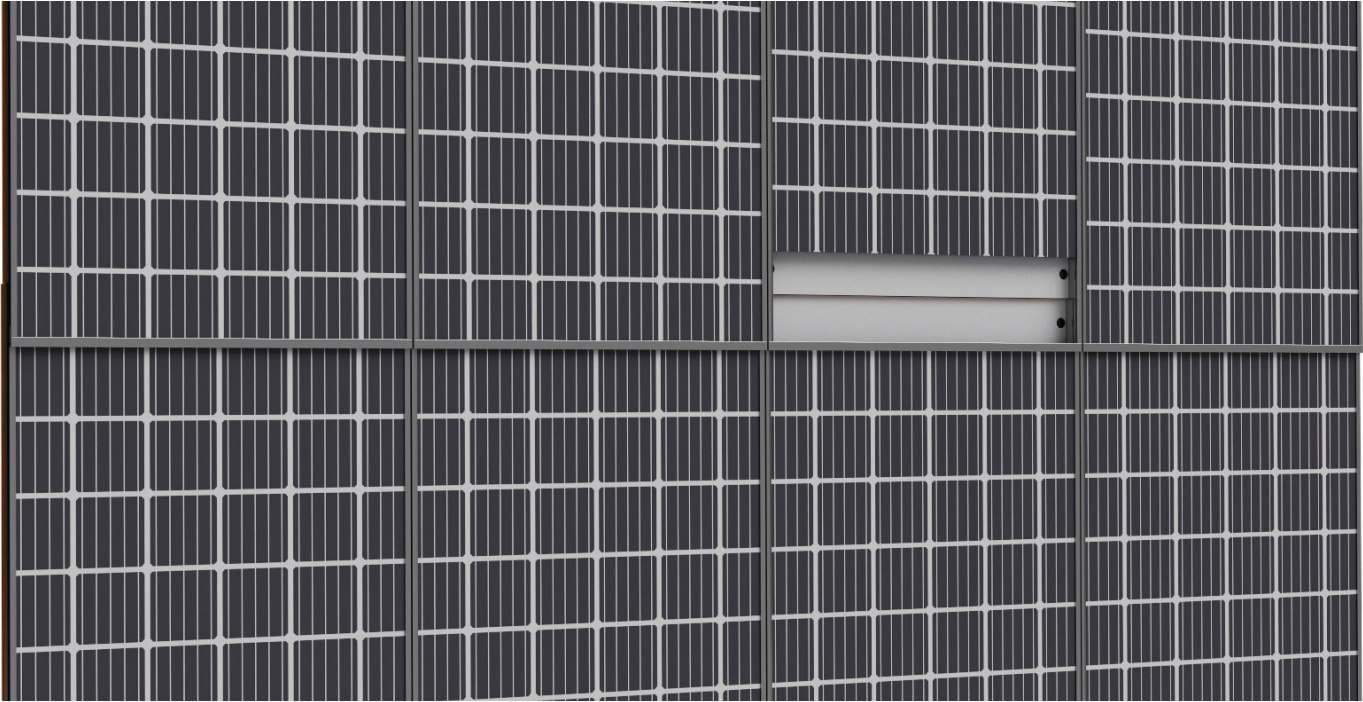

With the universal solar facade element, it is possible to easily open entire exterior facades for photovoltaic panels. The type of solar panel is irrelevant for the solar facade element. The system can be directly integrated into steel and concrete skeleton buildings. The minimal sloping position allows the facade elements to be covered vertically, creating a visually uniform exterior surface.

### ADVANTAGES

In addition to the universal mounting and the possibility of using PV panels from different manufacturers, the facade element itself already enables cooling of the PV panels. The integrated air duct provides an air flow that protects the solar cells from degradation.

- › **Easy mounting of the facade element**
- › **Thermal insulation can be integrated**
- › **Rear ventilation can be realized in the module**



- › Universal mounting for external facades (BiPV)
- › Integration of any PV panels
- › Cooling of solar cells through rear ventilation
- › Removal of individual facade elements from the compound
- › Easy detachment of a PV panel for better maintenance

Towards the building side, the thermal insulation is taken over by insulation material and a thermal insulation board, so that no heat loss occurs due to the air flow. In addition, the facade will be kept warm during winter and cold during summer.

## INSTALLATION

The mounting on the facade is first done via screws, which are fixed at the upper edge. After the sliding PV panel has been pushed up, the two lower screws are accessible and can be screwed in place. The inside is overall uniform and straight. Via a front panel, the PV panel can be pulled out of the profile separately during disassembly.

- › Insertion between vertical beams of the steel or concrete skeleton structure and fastened to them.
- › After screwing in the two upper screws, the PV panel is pushed up to fix the two lower screws.
- › Spacers are used between the vertical and transverse beams.
- › PV panel can be pulled out of the SFE-MH individually.
- › To do this, the PV panel is pushed up and the two lower retaining screws are loosened. This allows the SFE-MH to be angled slightly and provides access to the front panel.

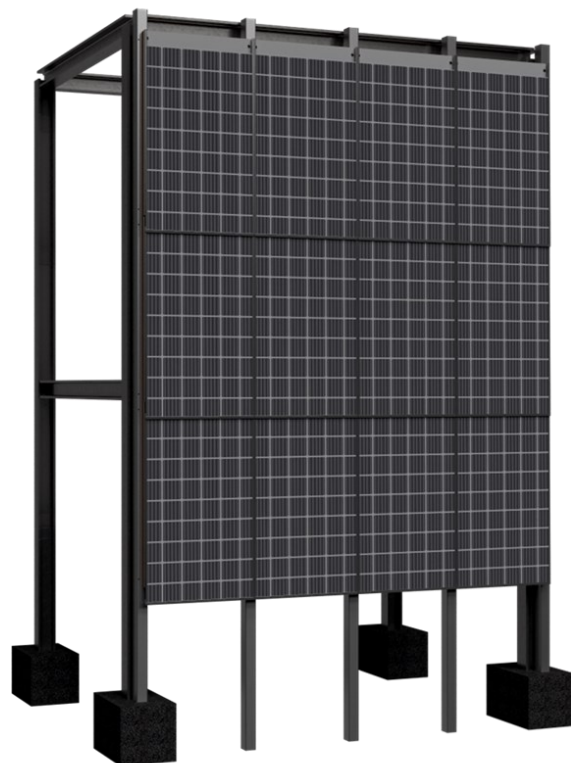
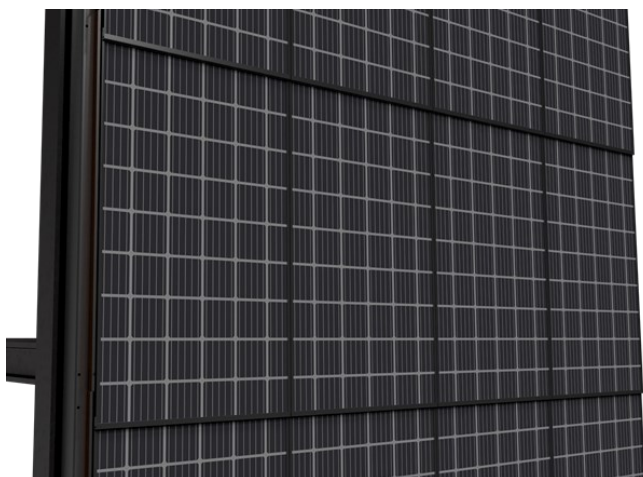

## TECHNICAL DATA

Parameter	SFE-MH
Color and power	Depending on panel
Housing material	Aluminium
Housing coating	Powder coating (all RAL colors possible)
Dimensions (L x W x H) [mm]	1700 x 1000 x 105
Connector	PV4-S
Mass	115.1 kg
Variants	<ol style="list-style-type: none"> <li>1. Basic: only panel and static holder</li> <li>2. With extra building insulation</li> <li>3. With extra cable canals and interior wall cladding</li> </ol>

# SOLAR WATER ELEMENT

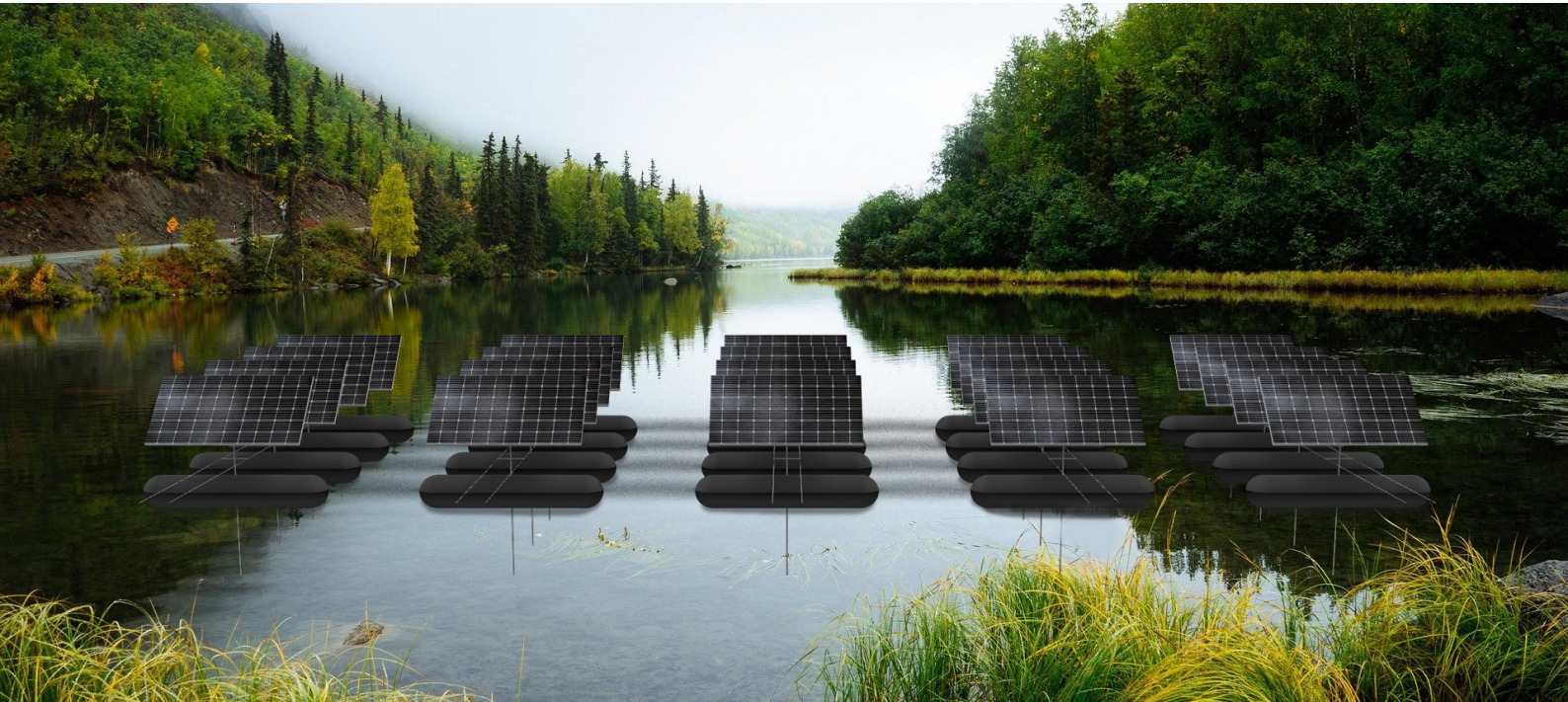

Water surfaces lend themselves to the use of photovoltaics due to their mostly unshaded location. Photovoltaic modules installed on water have a higher energy yield than comparable modules on land due to the reflection of the water and the solar radiation. At the same time, the water has a cooling effect, which also increases output.

Challenges exist in the active tracking of the solar modules and the mounting of the entire system in the landscape.

## GENERAL FUNCTIONALITY

The PV panel is located on a frame equipped with a scalable float. On the frame are receptacles for wire ropes, through which the system can be controlled in rows. A node on the ground provides translational fixation in two directions.

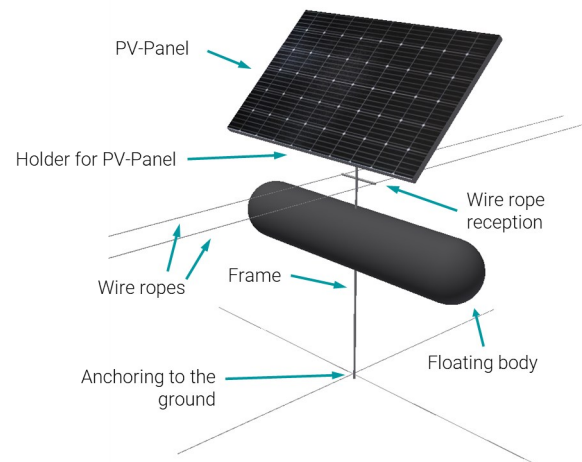

- › Universal mounting for PV panels on the water
- › Reflection of light, hardly any shading and cooling by the water increase energy output
- › Floating body provides buoyancy
- › Rotation and displacement are done by steel cables
- › Low motor power required as the whole system floats

## CONTROL

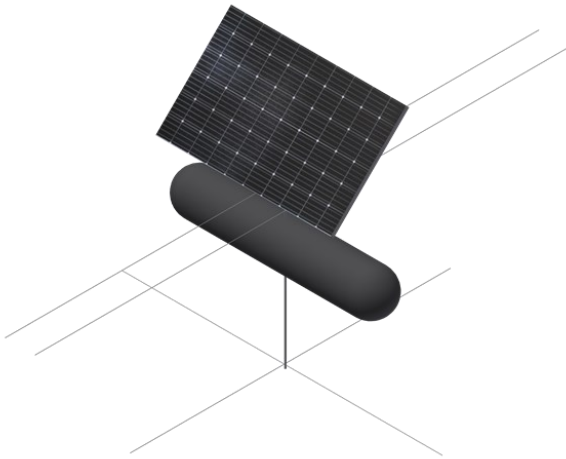

**Initial State:** The anchoring in the ground prevents floating away, the float provides sufficient buoyancy. The wire ropes connect and hold the entire system together.

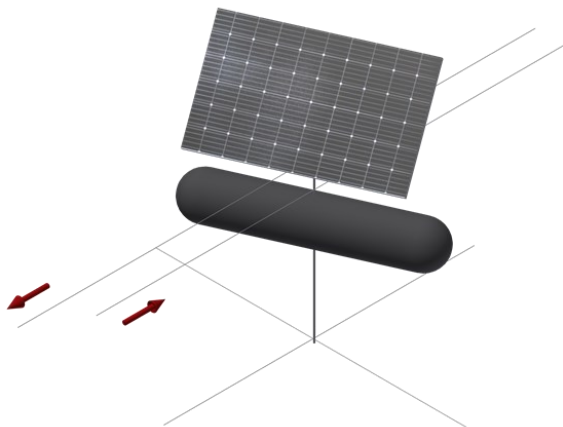

**Rotation around azimuth:** The wire ropes are pulled in opposite directions so that the PV panel can be optimally directed according to the course of the sun.

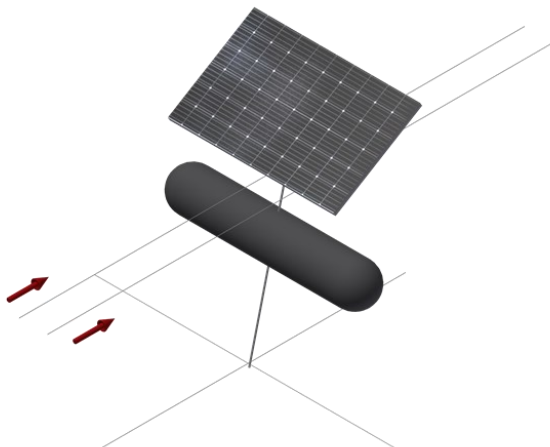

**Rotation in elevation direction:** When rotating around the abscissa, the wire ropes are pulled simultaneously. This allows the PV panel to always be positioned perpendicular to the sun. The motor power is only low in both cases, since the entire system floats. It is a 2-axis tracking system.

#### EXPLANATION: AZIMUTH

The azimuth is the angle between the south vector as a reference vector and the actual direction of the photovoltaic system in the horizontal plane.

In the northern hemisphere the azimuth angle corresponds to the directions 180° north, 270° east, 0° south and 90° west. In the southern hemisphere, the azimuth angle corresponds to 0° north, 90° east, 180° south and 270° west.

#### TECHNICAL DATA

Parameter	SWE-VG
Color and power	Depending on panel
Housing material	Aluminium
Housing coating	Powder coating (all RAL colors possible)
Floating body	Plastic blow mold
Drive type	Electric motor
Control type	2-axis system
Dimensions (L x W x H)	1850 x 1000 x 105

## SOLAR AGRICULTURAL ELEMENT MOUNTING SYSTEM

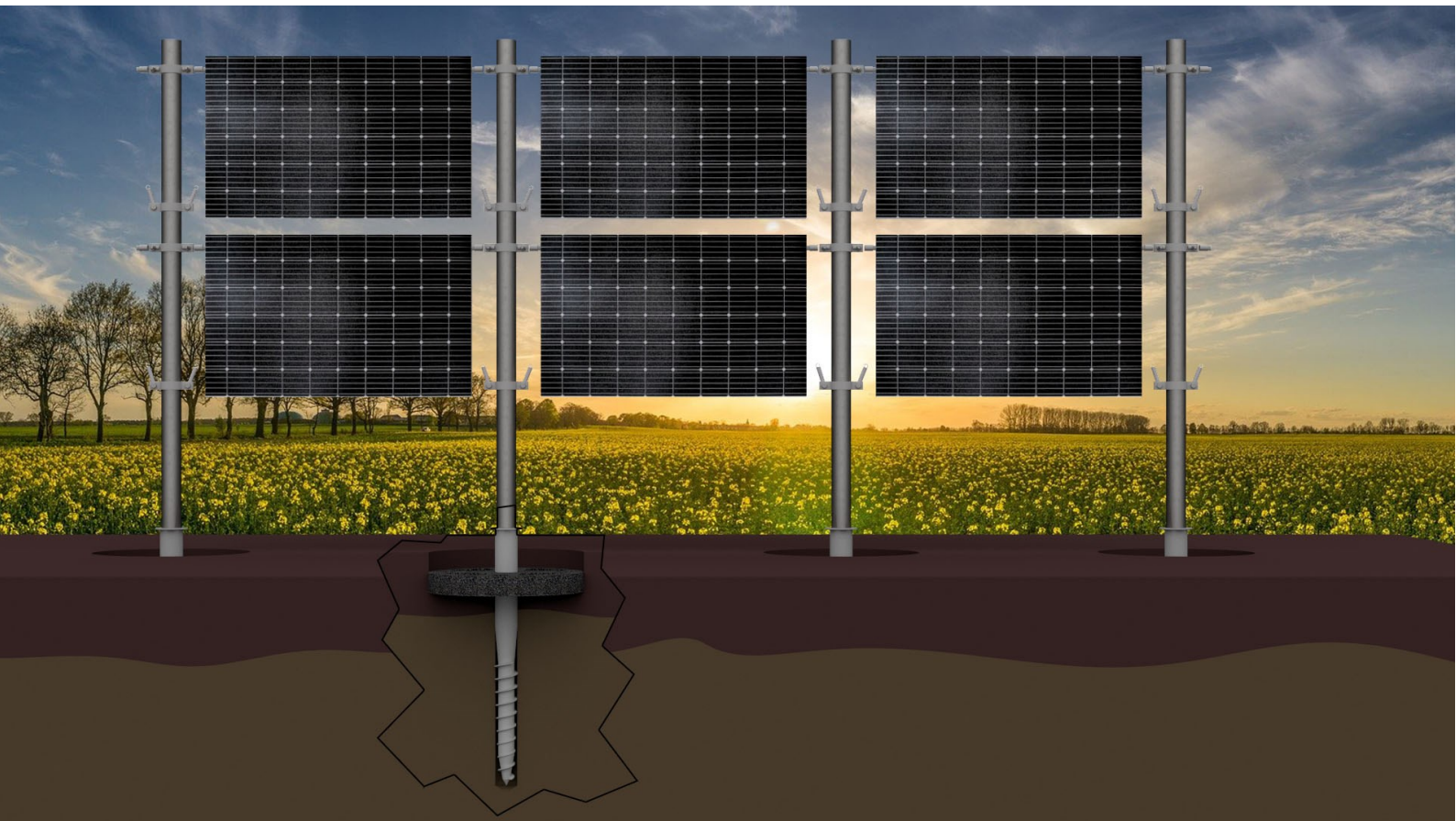

The mounting system for solar agricultural elements enables simple and rapid integration of bifacial photovoltaic modules on existing arable land.

The reasons for the development of agrarian systems lie in the multiple benefits: a power generation for one's own needs, the refinancing of the plant and the protection from excessive solar radiation for semi-shaded crops.

### PROBLEM

High wind loads that occur on open surfaces must be transferred to the ground. This leads to a high material consumption of concrete, which is used for this purpose.



- › Universal mounting for PV panels on agricultural land
- › Bracket with taproot principle for secure fastening
- › Higher bending moment possible (higher fences)
- › Rapid installation and immediate loading possible
- › Complete removal possible

In addition to high investment costs, the ecological disadvantages of ground sealing are challenges that need to be solved.

## SOLUTION

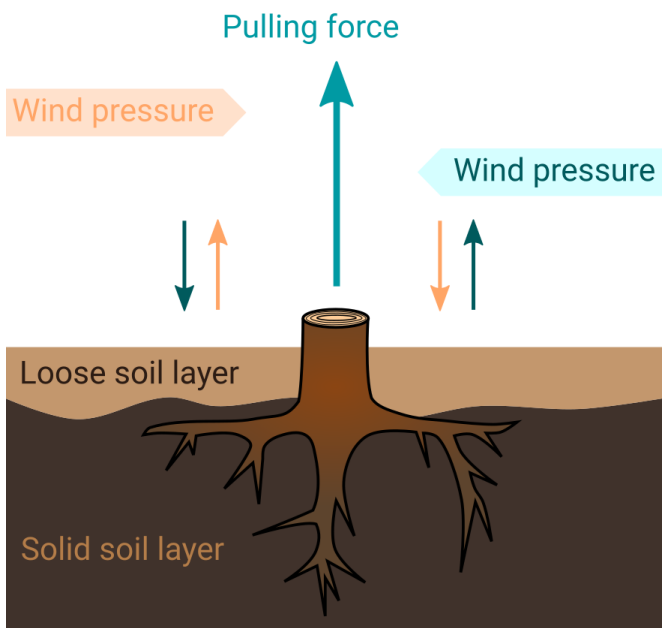

For the fence posts as a fastening system, the taproot principle is used. The special feature is the combination of a flexurally rigid concrete slab just below the turf and a screw-in sleeve that penetrates the solid soil.



## ADVANTAGES

The shear-pressure plate enables cost-effective assembly with proven machines and techniques, rapid installation and immediate loading. In contrast to previous systems, significantly less material is required, which is also easy to dismantle. The taproot principle allows higher bending moments to be introduced, making it possible to build taller fences.

## TECHNICAL DATA

Parameter	SAE-MS
Color and power	Depending on panel
Pole material	Stainless Steel
Earth screw sleeve material	Stainless Steel
Push pressure plate material	Steel-armoured concrete
Dimensions (L x W x H) [mm]	1800 x 960 x 3500
Mass	200 kg
Variants	Variable height possible 1. One panel in height 2. Two panels above each other



## SOLAR TRAFFIC ROUTE ELEMENT

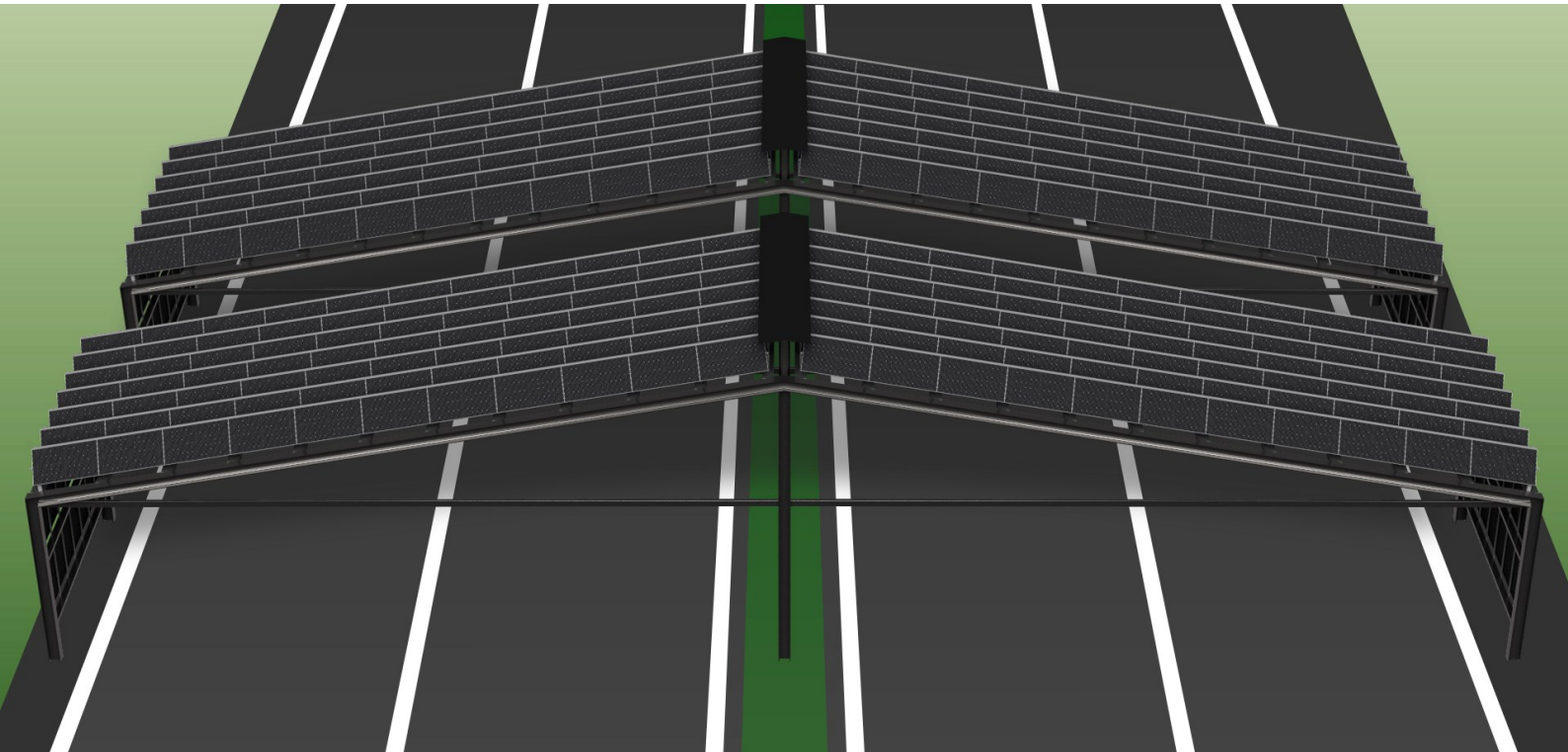

The solar traffic element makes built-up and sealed traffic areas usable. Highways, free-ways, etc. have great potential for multiple use. In addition, the road is protected from environmental influences and noise emissions are reduced.

- › No shading on highways
- › High potential for photovoltaics
- › Heat protection in summer



### SOLUTION

A skeletal steel beam structure provides mounts for photovoltaic modules that can be attached overhead and laterally. All modules are rotatably mounted and can be tilted for emergencies. The construction is based on cost-effective standard components and can be individually adapted to the road size.

- › Universal support for PV panels over traffic areas
- › Multiple use of highways, roads, etc.
- › Simple skeleton construction
- › Inclination of PV modules possible
- › Lightning smoke extraction provides increased fire protection



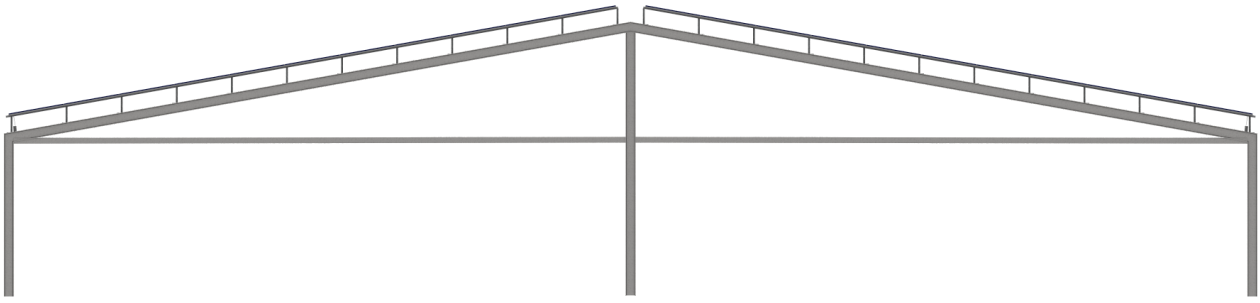

## ADVANTAGES

Due to the inclination of the modules, the system enables rapid smoke extraction in the event of a fire without the need for an elaborate additional construction. In addition, simple escape routes can be integrated in the lateral area. In case of heavy snowfall, the construction can also be relieved by inclining the modules.

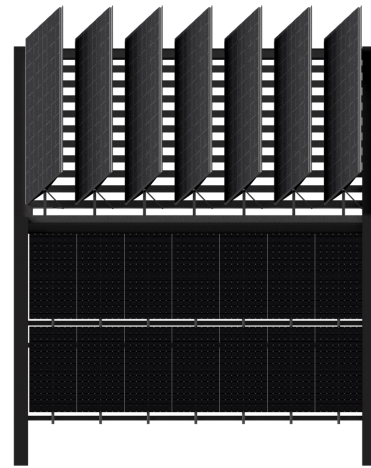
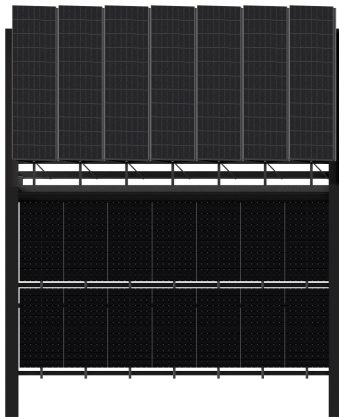

## EXPLANATION: TUNNEL

Tunnels are traffic route elements that are built above-ground or underground. In Germany, above-ground enclosures with a minimum length of 80 m are called tunnels as well.

Tunnel structures with a length of less than 80 m are called underpasses. Every tunnel has to meet special safety requirements in terms of fire and escape routes.

## TECHNICAL DATA

Parameter	STE
Color and power	Depending on panel
Construction material	Mild steel / concrete
Dimensions (L x W x H) [mm]	Variable depending on width of lanes
Mass	Depending on width
Variants	Variable width possible Up to 4 driving lanes each direction

## JUNCTION BOX PV



We are developing our own junction box in a flat design for BiPV to be able to use photovoltaic modules even more purposefully and efficiently. The junction box is particularly suitable for small-format systems, as it offers performance optimization at module level. In this way, PV modules with different inclinations and orientations can be interconnected in one string, offering freedom in module alignment.

### ADVANTAGES

The power optimization on module level includes a MPP tracking, which keeps each

- › Flat junction box
- › Suitable for small format photovoltaic systems
- › Interconnection of PV modules with different orientations and inclinations
- › Power optimization at module level
- › Safety shutdown reduces critical voltage to the short circuit voltage of the module

photovoltaic module in the range of the highest power. This leads to the maximum power output of the string.

The junction box offers the possibility of a safety shutdown at module level, which reduces the dangerous voltage in case of fire to the open-circuit voltage of each module. Since the DC main power lines are de-energized, there is no longer any danger to firefighters.

### TECHNICAL DATA

Parameter	Junction Box PV
Material	ASA
Dimensions (L x W x H) [mm]	67 x 75 x 15.7
Water Resistance	IP67
Cable	4 mm <sup>2</sup> , 0.47 m
Connector	Sunclix
Mass	0.3 kg

DON'T  
WANT  
TO  
MISS  
ANY  
**NEWS**  
IN  
THE  
**FUTURE?**



## › HIGH PERFORMANCE CHARGING SYSTEM

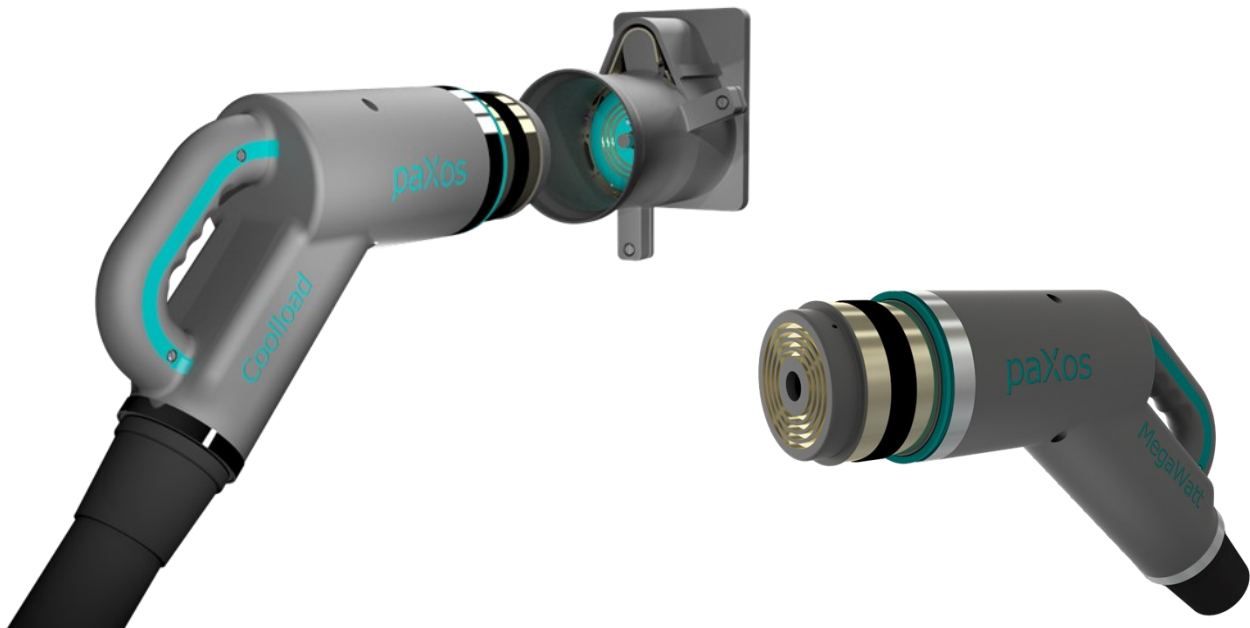

With a reliable charging infrastructure, the integration of fast charging systems is also realistic in the commercial vehicle sector. The electrification of cars, commercial vehicles, ships or even airplanes is based on high energy transfer between the power grid and the consumer to reduce downtimes and breaks and to make the means of transport economical.

### PROBLEM

In the future, the direct plug-in connection will be one of the bottlenecks. With the Cool-Load Megawatt, the charging power can be increased up to 4.5 MW by cooling so that the charging time is significantly reduced.

The stranding of the individual wires results in a flexible cable structure, so that the charging connection can be handled like an ordinary tank hose.



- › High Power Charging System for heavy duty vehicles
- › Charging power can be increased to 4500 kW
- › Radial connection between plug and socket increases contact surface
- › Direct cooling of the cables and connector with a non-conductive fluid
- › Funded research project

## FOUR FACTORS OF GOOD ELECTRICAL POWER TRANSMISSION

### 1. Large contact area and small transmission distance

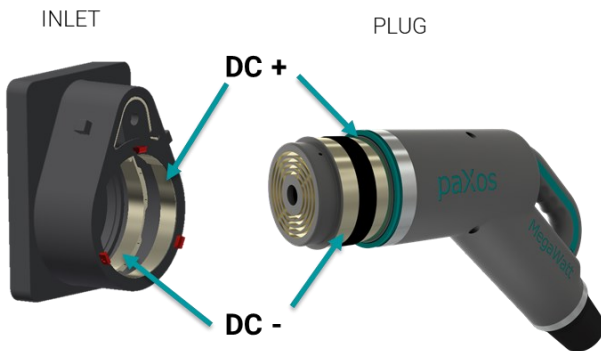

### 2. High contact pressure

The contact between plug and socket contact ring is achieved automatically with a „knee lever clamp“.

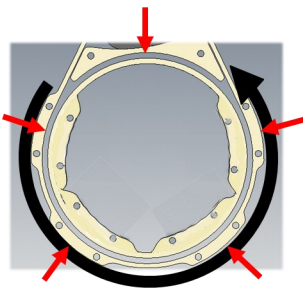

### 3. Grinding of contact surfaces

Grinding of the connectors surfaces normally takes place during the connection process. The contact ring of the socket tightens and grinds radially around the contact ring of the plug.

### 4. Cooling of contacts and cable

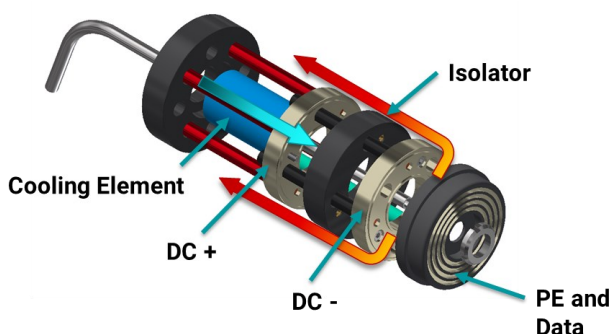

The contact rings and cable are cooled directly by a non-conductive fluid, which flows on the inside (plug) and outside (inlet) of the contact ring.

## CABLE

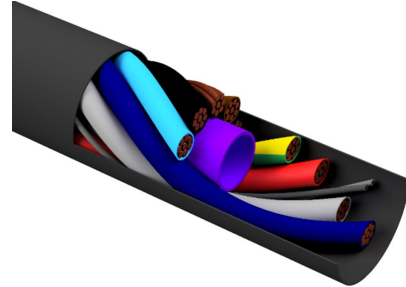

The stranding of the individual cable strands results in high flexibility. Thereby the inner surface is equipped with a heat reflecting material (OSHA) to provide a normal temperature on the outside. Inside, the coolant is supplied while it flows back between the individually insulated cores.

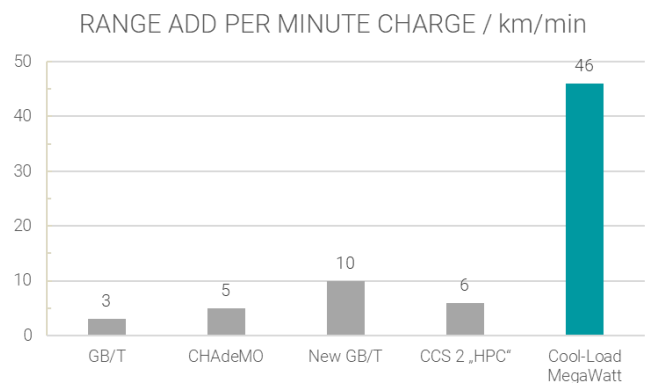

## TECHNICAL DATA

Parameter	Cool-Load Megawatt
Power	> 4500 kW (dc 100 %)
Nominal Voltage	1500 V
Nominal Current	3000 A
Contact Area	4250 mm <sup>2</sup>
Surface Pressure	> 100 N with mechanical connection system
Insertion Force	~ 0 N
Insertion Orientation	No orientation needed
Cooling	Direct contact cooling

## WHEEL HUB MOTOR AXIAL SUSPENDED

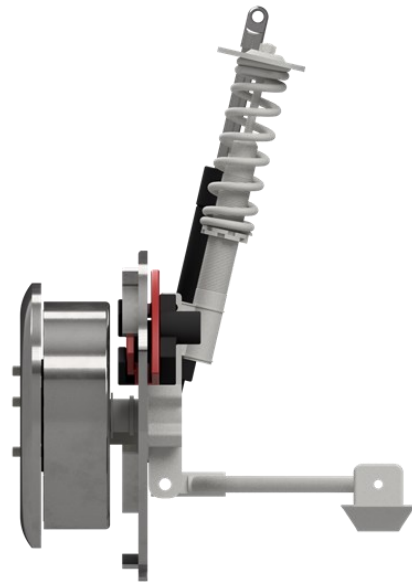

Wheel hub motors and near-wheel drives have not yet become established in the automotive sector. The reasons for this range from increased tire-sprung masses, which lead to a loss of comfort, to increased production costs.

From a driving dynamics and safety perspective, it is worth considering wheel hub drives. They lead to better driving performance and more precise control in critical situations - and in this way support the driver.

### REASONS FOR THE DEVELOPMENT

paXos has set itself the goal of thinking sustainably - also for drives in vehicles. We are developing a state-of-the-art machine that creates space inside the car. The engine, clutch and transmission are reduced to a single unit that is inconspicuously integrated into the installation space of the rim. A patented

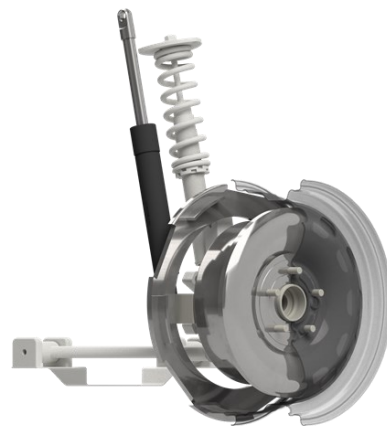

- › Axially arranged, switched reluctance machine
- › High efficiency in the partial load range
- › Reduction of tire-sprung masses due to suspension of the stator
- › No use of rare earths required
- › Cost-effective production possible

axially arranged switched reluctance machine is used, which uses the reluctance force to set the rotor in motion.

## SETUP

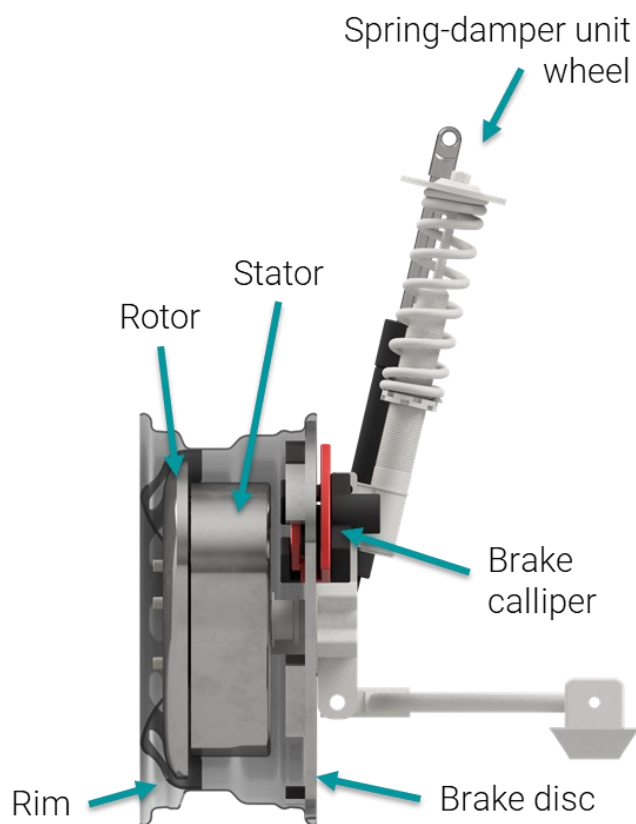

The separate suspension of the stator leads to advantages in terms of driving dynamics, since the stator is no longer tire-sprung. In addition, depending on the voltage level of the battery, only a DC / DC conversion is necessary.

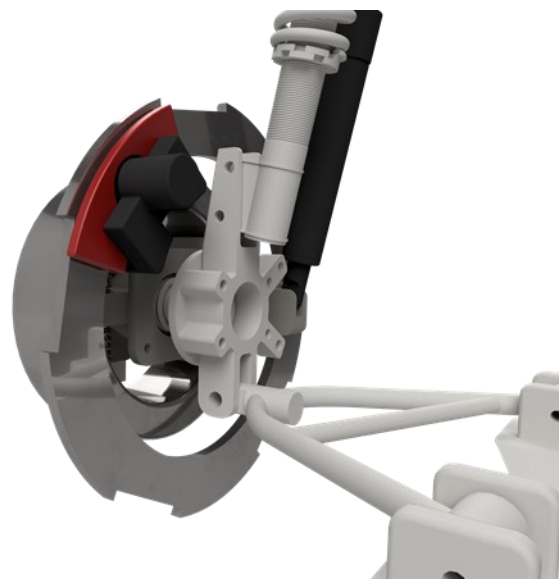

## SPECIFICATIONS

- › Novel design as axially switched reluctance machine (GRM)
- › Inconspicuously integrated in rim
- › Simplified design, low-cost production
- › External brake disc
- › Reduction of tire-sprung masses thanks to separate spring-damper unit for stator
- › McPherson / multi-link

## FEATURES

Unlike other electric motors, a switched reluctance machine does not require rare earths. Since both the stator and rotor have no permanent magnets, they have lower losses and a lower weight, compared to PMSM.

## EXPLANATION: RELUCTANCE FORCE

The reluctance force is based on the change of the magnetic resistance so that it is always minimal. A Switched Reluctance Machine (SRM) generates a changing magnetic field via windings in the stator. The rotor moves in such a way that the magnetic resistance is minimized.

## TECHNICAL DATA

Parameter	WHM paXos
Power	50 kW
Weight	35 kg
Rim size	17 inch
Suspension	McPherson, multi-link Separate spring-damper unit for stator
Brakes	Outside brake disc

## CHARGING POLE SMALL

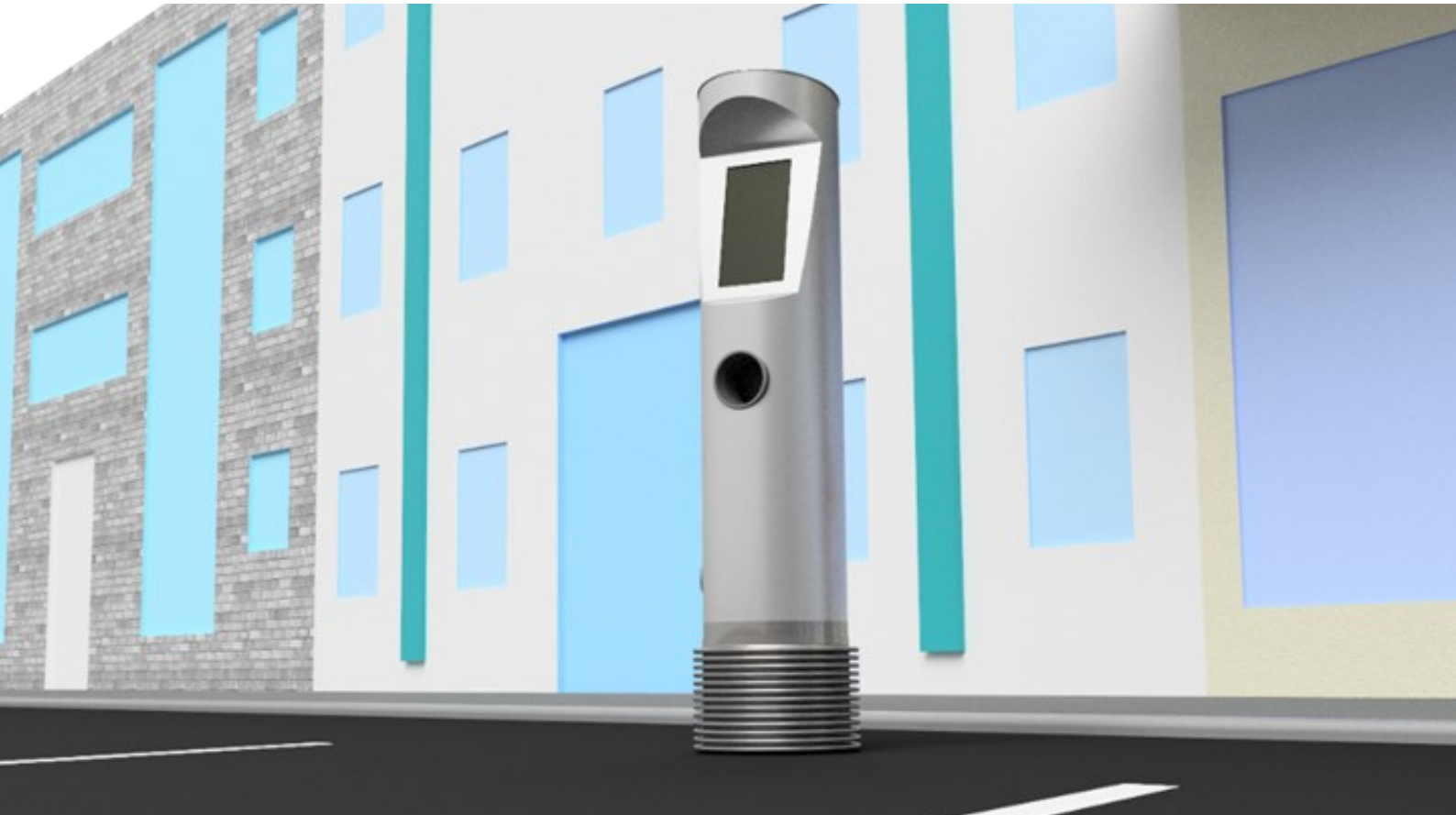

The expansion of the charging infrastructure is progressing worldwide and is placing ever new demands on charging points.

As the number of charging points increases, so does the risk of accidents due to crashes or parking bumps between vehicles and charging points. In such a case, the charging points are often replaced to ensure continued safety.

### REASONS FOR THE DEVELOPMENT

The fact that this process is resource- and labor-intensive lowers the profitability for the providers of corresponding systems. In addition, damage occurs due to environmental influences and vandalism, which negatively affects customer loyalty.



- › Clean, slim and round design made of stainless steel
- › Robust against parking bumps due to patented predetermined bending point
- › Cables and plugs directly accessible from outside
- › Electrically sensitive parts independent of the ground
- › Compatibility with fast charging systems



## REASONS FOR THE DEVELOPMENT

The small charging pole from paXos has a clean, functional design made of stainless steel that accommodates all the essential elements in the charging pole.

The large touchscreen enables easy operation, and individual operating systems can be easily integrated. Cables and plugs are directly accessible from the outside. Classic charging plugs or the paXos Cool-Load Megawatt can be used.

## ADVANTAGES

- › Large touch screen
- › Safe accommodation of all essential elements in the charging pole
- › Electrically sensitive parts independent of the floor
- › Predetermined bending points at the bottom of the housing
- › Built-in parts accessible via top plate

## FEATURES

The round design in stainless steel makes it possible to minimize damage from parking bumps and vandalism. The cable and plug are released after successful authentication (RFID or cell phone call), and the charging connection to the vehicle can then be established.

For maintenance, the internal components can be accessed via the maintenance plate in the head, so that repairs can be carried out quickly.

## EXTRACTABILITY

For the inconspicuous integration of charging points in city centers, the retractable version of the small charging pole can be used. This is

equipped with an automatic lowering of the head unit for aesthetics and additional protection against vandalism.

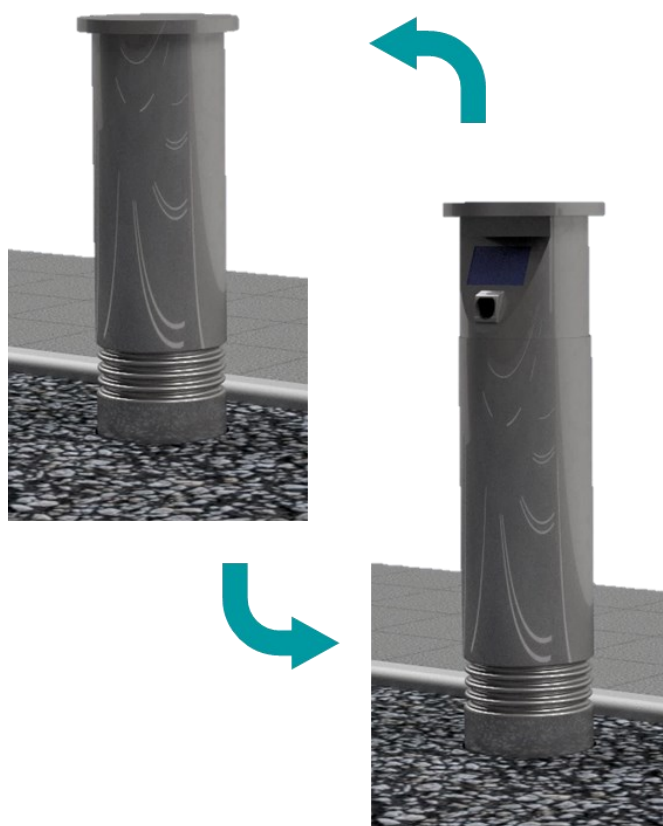

- › Touchscreen accessible after verification and extension for proper operation
- › Use with classic charging plugs
- › Robust housing
- › Maintenance access of the complete head unit

## TECHNICAL DATA

Parameter	Charging Pole Small
Power	Depending on charging system
Dimensions (diameter x H) [mm]	300 x 1200
Access protection	Via RFID
Cooling	Direct contact cooling possible

## CHARGING POLE TALL



The expansion of high-performance charging infrastructure is progressing worldwide and is essential for reliable and resilient electromobility. Increasing the number of charging points as well as securing them in the event of a crash represent challenges that must be implemented promptly.

- › Round design in stainless steel
- › Charging unit securely housed in lid
- › Charging cable and display remain locked until authentication
- › Predetermined bending point at floor level in the event of a crash
- › Maintenance access for quick and easy inspection

## REASONS FOR THE DEVELOPMENT

The charging stations currently on the market have the disadvantages that the charging cables are not integrated and are exposed to weather conditions during charging. In addition, significant weather events such as flooding pose the risk of permanent damage to the charging point.



Figure: Maintenance flap

- › No charging cable integrated
- › Installation parts difficult to reach
- › Cooling of the charging pole problematic
- › No predetermined bending points on the housing
- › Poor protection against vandalism

## ADVANTAGES

In the case of the large charging station, the cable and plug are locked in a column. After successful verification, they are released. The stainless steel column is strongly secured against vandalism and protected against scuffing, scratching or being stepped on.

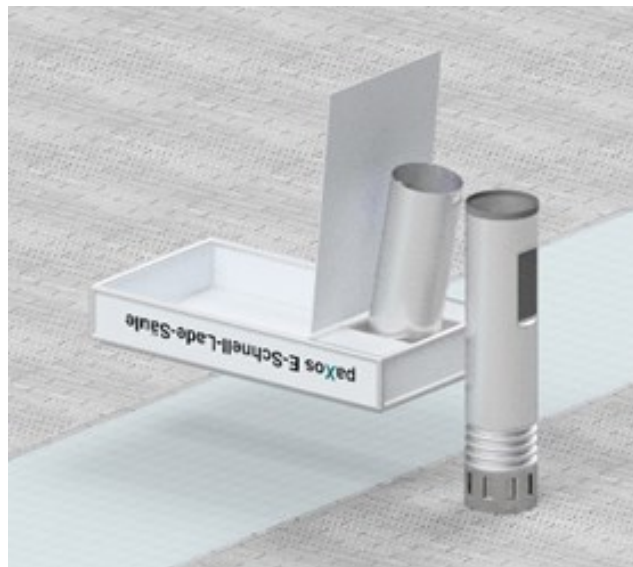

Figure: Direct access to the sensitive parts

All electrically sensitive parts are located above a height of 1 m above street level, so that they are secured in the event of a crash. A predetermined bending point at ground level ensures that the loading point is not damaged.

## MAINTENANCE

The maintenance flap makes it easy to reach the installed parts and to replace them if necessary. The working height is ergonomically designed. Despite the easy opening for service work, the charging pole remains closed in the event of an accident and offers protection from the weather during operation.

## TECHNICAL DATA

Parameter	Charging Pole Tall
Power	> 4500 kW (dc 100 %) 350 kW (CCS)
Nominal Voltage	1500 V
Nominal Current	3000 A
Dimensions (diameter x H) [mm]	300 x 2500
Access protection	Via RFID
Cooling	Direct contact cooling possible

## CHARGING POLE TOP-ROOF

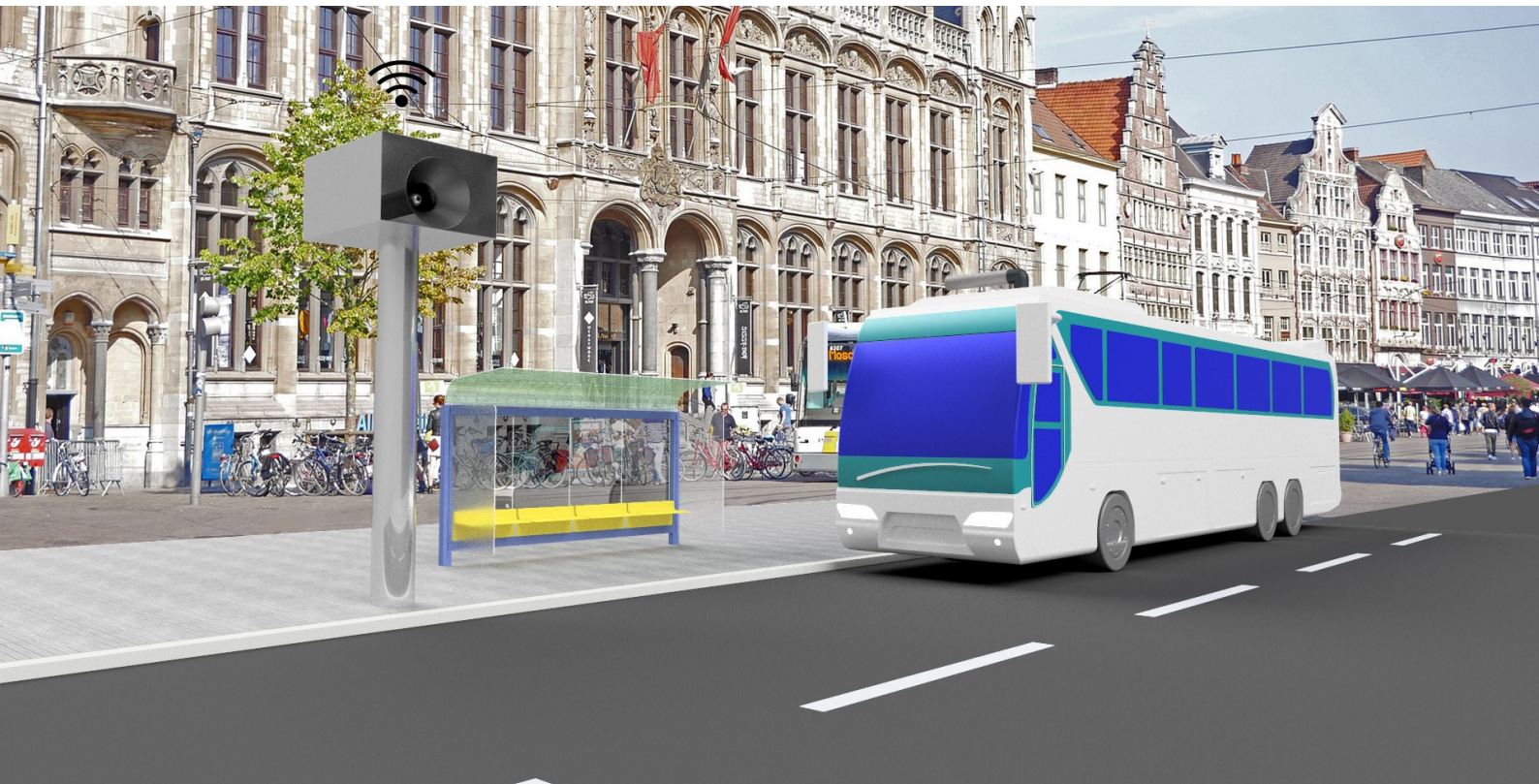

The expansion of the charging infrastructure is progressing worldwide and is essential for reliable and resilient electromobility in the commercial vehicle sector as well. Increasing the number of charging points and securing them in the event of a crash are challenges that must be met promptly.

- › Customizable charging station for commercial vehicle sector
- › Automated charging process
- › Direction-independent charging of the vehicle (front right or left)
- › Safe accommodation of all essential elements in the charging pole
- › Safety of the commercial vehicle against swaying of the body due to loading and unloading or wind load

The charging solutions currently available on the market have the disadvantage that heavy-duty vehicles cannot be charged reliably and safely. The dimensions of the charging cables and plugs continue to increase due to the higher charging capacities, so that manual operation will no longer be possible in the future.

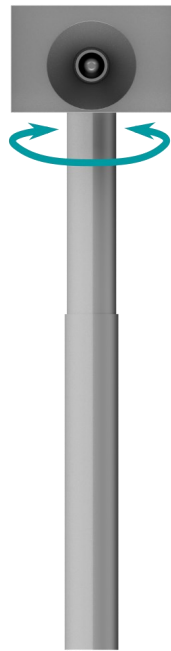
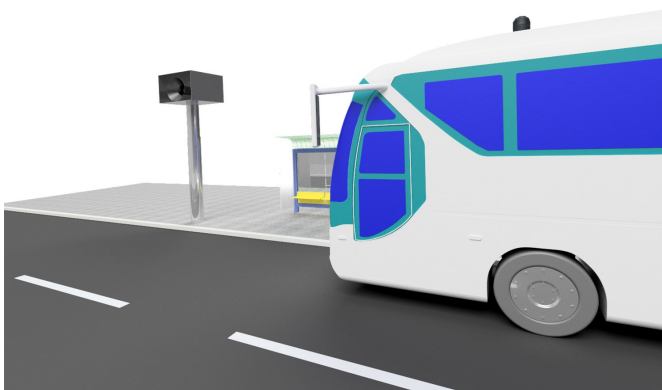

Figure: Adjustable charging unit

## ADVANTAGES

- › Automated charging process for use in commercial vehicles
- › Direction-independent charging of the vehicle (front right or left)



- › Increased safety in the event of a crash
- › Mechanical safety against unintentional driving off (also accident)
- › Safety of the commercial vehicle against swaying of the body due to loading and unloading or wind load

## FEATURES

The over-roof charging pole consists of a tubular stainless steel structure that protects against vandalism, with a flexible charging unit mounted on the upper end. This can be adjusted both in height and orientation. In this way, commercial vehicles can be charged largely independently of their standing position.

- › Realization of fast charging systems possible
- › Contactless verification by mobile data systems (Vehicle-2-Infrastructure)
- › Safe accommodation of all essential elements in the charging pole

## EXPLANATION: V2I

Vehicle-to-Infrastructure is the wireless exchange of data between vehicles and the road infrastructure. V2I communication is wireless and bidirectional, the infrastructure provides the vehicle with various information.

## TECHNICAL DATA

Parameter	Charging Pole Top-Roof
Power	Depending on charging system
Dimensions (diameter x H) [mm]	300 x 3500
Access protection	Via mobile data / Vehicle-2-Infrastructure (V2I)
Cooling	Direct contact cooling possible

# COMPANY

We look forward to the personal contact with you - be it as a future customer, employee or partner. Engineering services, project management and consulting are our passion, whether in small orders or large development projects. We are particularly strong in the cross-system challenges and can therefore handle projects holistically. We are looking forward to a sustainable and good cooperation in exciting projects.

We support you in your planning and questions in the areas of energy technology, automotive and industry. With our innovative in-house developments such as the solar roof tile or the charging plug, we are preparing for the future. Interdisciplinary execution of orders is our strength. The know-how flows in from all industries and areas to make your project successful.

## PAXOS IS DIFFERENT

- › We are self-financed.
- › We are focused on sustainability.
- › We are a real team & act like one.
  - › We live flat hierarchies & can therefore act / decide quickly.
- › We are lean & dynamic.
  - › We are experts: tech-savvy, highly innovative & at the same time solid business people.



[www.paXos.gmbh](http://www.paXos.gmbh)

## HARD FACTS



### Company:

- › Founded in 2015
- › 20 years of combined experience
- › self-financed
- › sustainable orientation
- › flat hierarchies / quick decisions
- › lean and dynamic

### Key areas:

- › Engineering/Technical Services/Consulting
- › Project Management for small and large projects
- › Commercial Services and Consulting from one source

### Excerpt of some customers:

Continental, Magna, ProGroup, Knorr Bremse, Webasto, CJ Automotive, Ficosa, Porsche, Ford, RheinEnergie, Hoberg & Driesch, Standard Profile, Stadtwerke Iserlohn



[www.paXos.solar](http://www.paXos.solar)

# SERVICES

We develop state-of-the-art solutions for our customers at our site in Langenfeld (Rhld.) and offer not only consulting and services, but also product realizations up to prototypes.

With three key industries we bring a lot of expertise and know-how from a variety of projects. Synergies can be found not only in engineering, but also in cross-industry topics such as consulting, project management, training and human resources management.

## CONSULTING



With our excellent consulting, we provide you with individual solutions for your technical and economic problems. Based on your strengths, we develop tailor-made concepts for you that enable you to be even more successful. Whether by adding to your range of services or adapting to the specific customer - goal: a sustainable and profitable business.

- › **Definition:** Analysis of the specific situation (problem & scope), definition of the project outcome, creation of work plans
- › **Measurement:** Data collection, determination of the actual situation, definition of measurement criteria
- › **Analysis:** Problem Structuring, building pro-

cess landscapes & maps, identification of possible weak points, planning of concrete measures

- › **Improvement:** Elaboration of concepts, support in decision making, monitoring, realization of individual solutions
- › **Control:** Final analysis to evaluate the solution, follow-up, lessons learnt

## THINK TANK



We not only advise, we have become an important player in the market in the field of innovation with a large number of patents, our own prototype workshop and testing facilities. In this brochure you will find many examples of how we set trends in innovations. We help you to identify precisely these trends for your com-



pany at an early stage and to implement them in appropriate products. Our focus is on the automotive and energy sectors, in particular renewable energies and electromobility.

## ENGINEERING



Whether as support for your company on site or as a complete development project for you at our location - we offer you a wide range of cooperation options. If you need a component adaptation or a complex overall development - our team will be happy to convince you with its competence. We are also happy to represent your company in the development teams of large OEMs - we have the know-how that makes you successful.

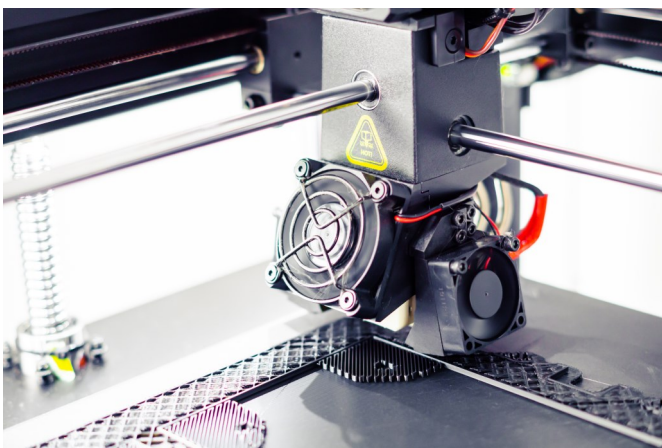

We offer you a broad portfolio of engineering services from component / system support, CAD design and CAE calculation to resident engineering and electrics / electronics development through to testing.

- › **Concept creation:** Status analysis, package studies, strategy development, construction sketches
- › **Construction:** Data conversion & maintenance in the systems CATIA V5, Inventor as well as the databases Teamcenter & Vault, 3D-modelling according to specifications, 2D drawing derivation according to customer standard, component design & optimization
- › **Simulation & Calculation:** Durability & strength, acoustics, fluid mechanics CFD, 3D optimization with CAESAS Mantium Flow
- › **Prototyping:** Small parts from plastic & metal, own workshop with extensive tools & machines, rapid prototyping
- › **Test & Validation:** Define test conditions, test coordination & execution, preparation of measurement results & analyses

## PROJECT MANAGEMENT



We offer you a comprehensive package in the area of project management from the first planning to commissioning and beyond. Everything from a single source, competent and reliable. With a wide range of project management know-how, a high level of motivation and experience from other industries, we react flexibly to situations and think sustainably.



Everything "new" in your company - new production facilities / products / processes / software etc. - is implemented through projects, which come to you as additional tasks. The implementation of projects, project management, is therefore one of the most important success factors for your company.

- › **Initialization:** Feasibility study, preparation of initialization, definition of project scope & objectives, (project) communication, approval procedures (BlmSchG)
- › **Planning:** Project definition, risk management, scheduling & coordination, budgeting, contract design & tracking, contract negotiations
- › **Execution:** Cost & performance control, determination of deviations (target–actual), report management, claim management
- › **Commissioning:** Progress tracking, critical path analysis, project control, construction & installation supervision, quality control

The paXos project management team is specialized in advising, accompanying and supporting you in your projects. Our employees have the following project management certifications: PMI / Prince2 / GPM IP-MA. Together with you we realize your projects for a successful future of your company.

## TRAINING



As a consulting company, we train almost all areas that are also offered as a range of services. From Engineering, CAx, PLM and Project Management to soft skill and office automation training: Let us convince you of our diverse offering!

- › **Technical Trainings**
- › **Project Management**
- › **MS Office**
- › **Soft Skills**

Our trainers and speakers have years of training and professional expertise and will be happy to develop individual training concepts tailored to your specific needs.

## HR CONSULTING



Thanks to our years of experience in recruiting for our major clients and in developing successful employer brands, we can provide you with comprehensive support in establishing successful HR concepts, strategies and processes.

As employers, companies are more than ever exposed to constant competition for the best employees. An attractive overall HR concept is indispensable for successful recruitment and long-term loyalty to the company. The various HR topics are closely intertwined, so that they can only lead to the greatest possible success if they are combined.

# JOURNEY DIRECTIONS



## ARRIVAL BY CAR

### Coming from the North

- › Take the A59, direction Cologne / Leverkusen
- › Leave the motorway at the exit 24 – Richrath and turn left at the traffic lights onto Berghausener Str.
- › Turn left at the next traffic lights onto Karl-Benz-Straße

### Coming from the East, South and West

- › Take the A59, direction Düsseldorf
- › Leave the motorway at the exit 24 – Richrath and continue straight ahead at the traffic lights onto Karl-Benz-Straße

### Further route

- › Turn right at the first intersection and follow the road
- › The building is on the right hand side, parking spaces are on the right hand side behind the building

## ARRIVAL BY PUBLIC TRANSPORT

### From the airport

- › From Cologne/Bonn airport, take the S-Bahn

(suburban train) lines 12, 13 or 19 to Cologne Central Station. Take the S6 in the direction of Essen Hbf.

- › From Düsseldorf airport, take the S-Bahn line 11 or the RE lines 1 or 5 to Düsseldorf Central Station. Take the S6, direction Köln-Nippes or Köln-Worringen.
- › Exit the train at „Langenfeld-Berghausen“ and walk about 350 meters

### From the main station

- › From Cologne Central Station, take the S6 towards Essen Central Station
- › From Düsseldorf Central Station, take the S6 towards Köln-Nippes or Köln-Worringen
- › Exit the train at „Langenfeld-Berghausen“ and walk about 350 meters

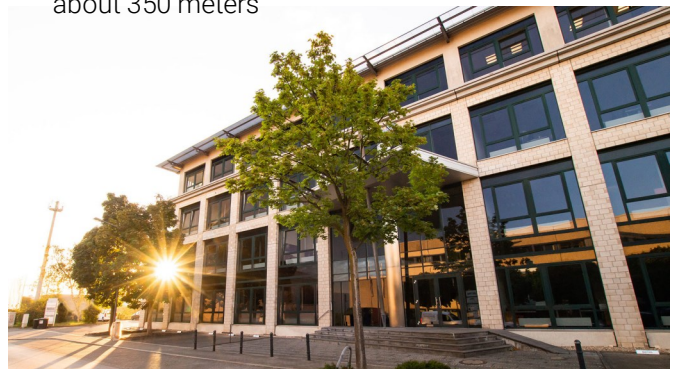



# IMPRINT

paXos Consulting & Engineering GmbH & Co. KG  
Karl-Benz-Str. 9  
D-40764 Langenfeld

## REGISTER ENTRY

Entry in: Commercial Register  
Register Number: HRA 24870  
Register Court: District Court Düsseldorf

### Represented by

paXos Management GmbH  
Karl-Benz-Str. 9  
D-40764 Langenfeld (Rhld.)

Entry in: Commercial Register  
Register Number: HRB 82997  
Register Court: District Court Düsseldorf

### Professional Representation

Peter Hakenberg, Managing Director  
Janina Kaergel, Managing Director  
Karsten Birkholz, Authorized Representative  
Guido Schumacher, Authorized Representative  
Stefan Puczynski, Authorized Representative

## CONTACT INFORMATION

Telephone: +49 (0) 2173 200 43 30  
E-Mail: info@paXos.gmbh

## VAT NUMBER

VAT identification number in accordance with  
§27 a of the German VAT act: DE299685862

# paXos

## paXos Consulting & Engineering GmbH & Co. KG



Karl-Benz-Str. 9  
D – 40764 Langenfeld (Rhd.)



+49 (0)2173 200 43 30



info@paXos.gmbh



[www.paXos.gmbh](http://www.paXos.gmbh)



[www.paXos.solar](http://www.paXos.solar)